



Designation: F1430/F1430M – 20

Standard Test Method for Acoustic Emission Testing of Insulated and Non-Insulated Aerial Personnel Devices with Supplemental Load Handling Attachments¹

This standard is issued under the fixed designation F1430/F1430M; the number immediately following the designation indicates the year of original adoption or, in the case of revision, the year of last revision. A number in parentheses indicates the year of last reappraisal. A superscript epsilon (ϵ) indicates an editorial change since the last revision or reappraisal.

1. Scope

1.1 This test method describes a procedure for acoustic emission (AE) testing of aerial personnel devices (APDs) with supplemental load handling attachments.

1.1.1 *Equipment Covered*—This test method covers the following types of vehicle-mounted aerial personnel devices with supplemental load handling attachments:

1.1.1.1 Extensible-boom APDs,

1.1.1.2 Articulating-boom APDs, and

1.1.1.3 Any combination of 1.1.1.1 and 1.1.1.2.

1.1.2 *Equipment Not Covered*—This test method does not cover any of the following equipment:

1.1.2.1 Aerial personnel devices without supplemental load handling attachments,

1.1.2.2 Digger-derricks with platform,

1.1.2.3 Cranes with platform, and

1.1.2.4 Aerial devices with load-lifting capabilities located anywhere other than adjacent to the platform.

NOTE 1—This test method is not intended to be a stand-alone NDT method for the verification of the structural integrity of an aerial device. Other NDT methods should be used to supplement the results.

1.2 The AE test method is used to detect and area-locate emission sources. Verification of emission sources may require the use of other nondestructive test (NDT) methods, such as radiography, ultrasonics, magnetic particle, liquid penetrant, and visual inspection. (**Warning**—This test method requires that external loads be applied to the superstructure of the vehicle under test. During the test, caution must be taken to safeguard personnel and equipment against unexpected failure or instability of the vehicle or components.)

1.3 The values stated in either SI units or inch-pound units are to be regarded separately as standard. The values stated in each system are not necessarily exact equivalents; therefore, to

¹ This test method is under the jurisdiction of ASTM Committee F18 on Electrical Protective Equipment for Workers and is the direct responsibility of Subcommittee F18.55 on Inspection and Non-Destructive Test Methods for Aerial Devices.

Current edition approved Aug. 1, 2020. Published September 2020. Originally approved in 1992. Last previous edition approved in 2018 as F1430/F1430M–18. DOI: 10.1520/F1430_F1430M-20.

ensure conformance with the standard, each system shall be used independently of the other, and values from the two systems shall not be combined.

1.4 *This standard does not purport to address all of the safety concerns, if any, associated with its use. It is the responsibility of the user of this standard to establish appropriate safety, health, and environmental practices and determine the applicability of regulatory limitations prior to use.*

1.5 *This international standard was developed in accordance with internationally recognized principles on standardization established in the Decision on Principles for the Development of International Standards, Guides and Recommendations issued by the World Trade Organization Technical Barriers to Trade (TBT) Committee.*

2. Referenced Documents

2.1 *ASTM Standards:*²

E94 Guide for Radiographic Examination Using Industrial Radiographic Film

E114 Practice for Ultrasonic Pulse-Echo Straight-Beam Contact Testing

E164 Practice for Contact Ultrasonic Testing of Weldments

E569 Practice for Acoustic Emission Monitoring of Structures During Controlled Stimulation

E650 Guide for Mounting Piezoelectric Acoustic Emission Sensors

E750 Practice for Characterizing Acoustic Emission Instrumentation

E976 Guide for Determining the Reproducibility of Acoustic Emission Sensor Response

E1316 Terminology for Nondestructive Examinations

E1417/E1417M Practice for Liquid Penetrant Testing

E1444/E1444M Practice for Magnetic Particle Testing

F914 Test Method for Acoustic Emission for Aerial Personnel Devices Without Supplemental Load Handling Attachments

² For referenced ASTM standards, visit the ASTM website, www.astm.org, or contact ASTM Customer Service at service@astm.org. For *Annual Book of ASTM Standards* volume information, refer to the standard's Document Summary page on the ASTM website.

F2174 Practice for Verifying Acoustic Emission Sensor Response

2.2 *Other Standards:*

ANSI A92.2 Standard for Vehicle-Mounted Elevating and Rotating Aerial Devices³

ASNT SNT-TC-1A Recommended Practice for Personnel Qualification and Certification in Nondestructive Testing⁴

dB Value	Acoustic Emission Reference Scale	
	Voltage At Sensor Output	Voltage At Integral Preamp Sensor Output (40-dB Gain)
0	1 μ V	100 μ V
20	10 μ V	1 mV
40	100 μ V	10 mV
60	1 mV	100 mV
80	10 mV	1 V
100	100 mV	10 V

3. Terminology

3.1 *Definitions:*

3.1.1 *acoustic emission (AE)*—the class of phenomena whereby elastic waves are generated by the rapid release of energy from a localized source or sources within a material, or the transient elastic wave(s) so generated. Acoustic emission is the recommended term for general use. Other terms that have been used in AE literature include (1) stress wave emission, (2) microseismic activity, and (3) emission or acoustic emission with other qualifying modifiers.

3.1.2 *amplitude (acoustic emission signal amplitude)*—the peak voltage of the largest excursion attained by the signal waveform from an emission event.

3.1.3 *amplitude distribution*—a display of the number of acoustic emission events with signals that exceed an arbitrary amplitude as a function of amplitude.

3.1.4 *articulating-boom aerial device*—an aerial device with two or more hinged boom sections.

3.1.5 *attenuation*—the loss of energy per unit distance, typically measured as loss of signal peak amplitude with unit distance from the source of emission.

3.1.6 *channel*—an input to the main AE instrument that accepts a preamplifier output.

3.1.7 *commoned*—two or more sensors interconnected such that the sensor outputs are electronically processed by a single channel without differentiation of sensor origin.

3.1.8 *count* also *acoustic emission count*, *n*—the number of times the acoustic emission signal amplitude exceeds a preset threshold during any selected portion of a test.

3.1.9 *decibel (dB)*—the logarithmic expression of a ratio of two single peak amplitudes. A reference scale expresses the logarithmic ratio of a single peak amplitude to a fixed reference amplitude.

$$\text{Signal peak amplitude (dB)} = 20 \log_{10}(A_1/A_0)$$

where:

A_0 = 1 μ V at the sensor output (before amplification), and
 A_1 = peak voltage of the measured acoustic emission signal.

³ Available from American National Standards Institute (ANSI), 25 W. 43rd St., 4th Floor, New York, NY 10036, <http://www.ansi.org>.

⁴ Available from American Society for Nondestructive Testing (ASNT), P.O. Box 28518, 1711 Arlingate Ln., Columbus, OH 43228-0518, <http://www.asnt.org>.

3.1.10 *insulated aerial personnel device (IAPD)*—any device (extensible or articulating) which is designed primarily to position personnel and may be equipped with a supplemental load handling attachment.

3.1.11 *event (acoustic emission event)*—a local material change giving rise to acoustic emission.

3.1.12 *event count (N_e)*—the number obtained by counting each discerned acoustic emission event once.

3.1.13 *extensible-boom aerial device*—an aerial device, except the aerial ladder type, with a telescopic or extensible boom.

3.1.14 *first-hit*—a mode of operation of AE monitoring equipment in which an event occurring on one channel will prevent all other channels from processing data for a specified period of time. The channel with a sensor closest to the physical location of the emission source will then be the only channel processing data from that source.

3.1.15 *insulated aerial device*—an aerial device designed with dielectric components to meet a specific electrical insulation rating.

3.1.16 *insulator*—any part of an aerial device such as, but not limited to, the upper boom, lower boom or supporting structure, made of a material having a high dielectric strength, usually FRP or the equivalent.

3.1.17 *noise*—any undesired signal that tends to interfere with the normal reception or processing of the desired signal.

3.1.18 *non-destructive testing*—the examination by various means of devices and their components without alteration of the original components, so that they may function as before.

3.1.19 *non-overcenter*—the feature of an aerial device is such that the upper boom cannot travel past vertical orientation with respect to the ground.

3.1.20 *overcenter*—the feature of an aerial device is such that the upper boom travels past vertical orientation with respect to the ground.

3.1.21 *qualified personnel*—personnel who, by possession of a recognized degree, certificate, professional standing, or skill, and who, by knowledge, training, and experience, have demonstrated the ability to deal with problems relating to the subject matter, the work, or the project.

3.1.22 *rated boom capacity (RBC)*—the maximum allowable capacity of the boom which is calculated by combining the platform capacity and the capacity of the supplemental load handling attachment at zero degrees and fully retracted.

3.1.23 *signal (emission signal)*—a signal obtained by detection of one or more acoustic emission events.

3.1.24 *supplemental load*—a load which may be affixed to a supplemental load-handling attachment on an insulated aerial personnel device.

3.1.25 *supplemental load attachment capacity (SLAC)*—the maximum allowable load, as stated by the aerial device manufacturer, which may be affixed to the supplemental load-handling attachment at specified positions of the attachments.

3.1.26 For definitions of other terms in this test method, refer to Terminology E1316.

3.2 *Definitions of Terms Specific to This Standard:* (see Fig. 1 and Fig. 2):

3.2.1 *elbow*—the structure connecting the upper boom to the lower boom, about which one boom articulates relative to the other.

3.2.2 *elbow pin*—the horizontal pin about which the upper boom rotates relative to the lower boom.

3.2.3 *lift cylinder*—the hydraulic cylinder that lifts the lower boom and the extensible boom(s).

3.2.4 *lower boom*—the structural member, attached to a turntable or base, that supports the upper boom.

3.2.5 *lower-boom cylinder*—the hydraulic cylinder that articulates the lower boom.

3.2.6 *lower-boom insulator*—the part of the lower boom made of high-dielectric strength material (usually fiberglass reinforced plastic or equivalent).

3.2.7 *lower-boom pin*—the horizontal pin about which the lower boom is raised and lowered relative to the turntable.

3.2.8 *outriggers*—the structural members that, when properly extended or deployed on firm ground, assist in stabilizing the vehicle on which the aerial device is mounted.

3.2.9 *pedestal*—the stationary base of the aerial device that supports the turntable.

3.2.10 *platform*—the personnel-carrying component of an aerial device, such as a bucket, basket, stand, or equivalent.

3.2.11 *platform pin*—the horizontal pin about which the platform rotates relative to the upper boom.

3.2.12 *rated platform capacity (RPC)*—the maximum load as stated by the manufacturer for which an aerial device is designed to operate, consisting of the combined weight of the personnel and all items carried on or in the platform.

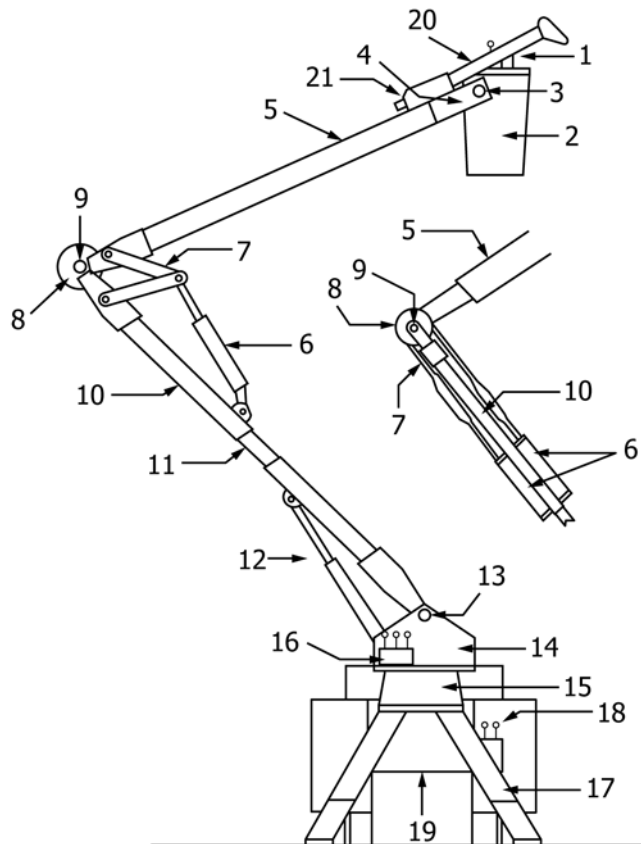

- | | | |
|-------------------------------|--------------------------|---|
| 1. Upper Controls | 8. Elbow | 15. Pedestal |
| 2. Platform | 9. Elbow Pin | 16. Lower Controls |
| 3. Platform Pin | 10. Lower Boom | 17. Outriggers |
| 4. Upper Boom Tip | 11. Lower Boom Insulator | 18. Outrigger Controls |
| 5. Upper Boom | 12. Lower Boom Cylinder | 19. Stabilizers |
| 6. Upper Boom Cylinder | 13. Lower Boom Pin | 20. Supplemental Load Handling Attachment Arm |
| 7. Upper Boom Drive Mechanism | 14. Turntable | 21. Supplemental Load Handling Attachment Bracket |

FIG. 1 Articulating-Boom APD Nomenclature Diagram